

Hydrodynamic™ Building Sets



Hydrodynamic™
Starter Set

HYDRO206

1/87 scale of real
manufacturing plants
(HO scale)



Hydrodynamic™
Deluxe Set

HYDRO306

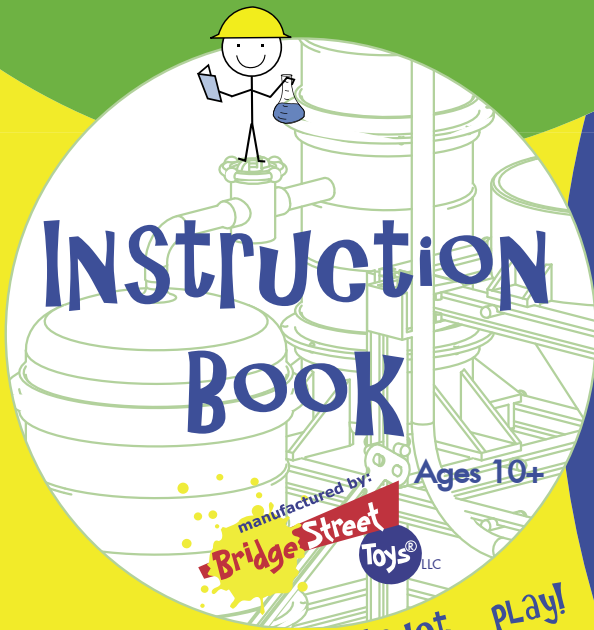

deSIGN... CONSTRUCT... play!

 **WARNING:**
CHOKING HAZARD - small parts
Not for children under 3 yrs.

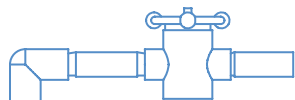

What's inside

Curious about building?	2
Intro to HYDRODYNAMIC™ Building Sets	3
Listing of parts in the sets	4
How the parts work	6
Tank assemblies	8
Models you can build	10
Progressive building instructions	12
Schematic	14
Did you know?	15
Contact us	16

About Bridge Street Toys

A privately held company, Bridge Street Toys is located in a suburb of Boston, Massachusetts. The company was founded by two engineers who strive to provide fun products that will inspire children to pursue careers in engineering, architecture, and technology.

About Girder & Panel™

Girder & Panel™ differs from other construction sets in that it lets children experiment with real engineering principles. The sets, which are perfect for science fair projects, allow the builder to investigate and create structures that are both tall and strong. Originally introduced by *Kenner Products* in the 1950's, there is an entire generation of engineers and architects who have many fond memories of playing with this set as children. Fifty years later, we are proud to be able to bring this inspirational toy back to market!

Some Of The Buildings You Can Construct

(pictures on page 10–11) Remember you can make your own variations and designs – the possibilities are endless!



Tektön™ Plaza Building



Tektön™ Bank

Are you curious about

How buildings are made?

How bridges work?

How chemical plants operate?

The Girder and Panel®, Bridge & Turnpike™, and HYDRODYNAMIC™ building sets were developed to help answer these questions! The building sets are designed to be replicas of actual buildings and bridges using a 1/87 scale (also known as HO

scale). Investigate the strongest structure for a tall building with the Girder and Panel® set.

Or the strongest design for a bridge with the Bridge and Turnpike™ set.

Or have fun pumping water through tanks and changing the water flow by opening and closing valves with the HYDRODYNAMIC™ set!

These classic sets help you understand and test the basic concepts of building strength (physics) and how water moves (fluid dynamics) in a fun, and creative way.

The parts in each of these sets are interchangeable with the other sets, and the sets can be combined to create entire cities complete with office buildings, airports, highways, and manufacturing plants.

Design...

Construct...

Play!

Introduction to HYDRODYNAMIC™ Building Sets

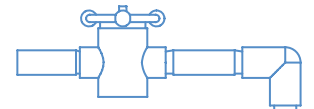

Build a model of a manufacturing plant with working tanks, pipes, valves and pump with this unique construction toy. Model an ice cream factory, a water treatment plant, an oil refinery, ... design your facility, build it, then add water for hours of fun!

The Deluxe Set includes an electric pump and at least one of each tank. The Starter Set includes a hand pump instead of the electric pump and some of the tanks, but not all of them. The Starter Set comes in the same size tray as the Deluxe Set so that it can easily be expanded by adding the Spare Tanks Kit, the Pipes and Valves Kit, and other spare parts.

Discover how a siphon works. Balance the flow through the plant by adjusting the valves. This set teaches the basic principles of fluid dynamics in a fun, creative way. The HYDRODYNAMIC™ Building sets are also great tools for conducting middle and high school level science fair projects - use the set to investigate the best filtration material for cleaning dirty water!

The HYDRODYNAMIC set is HO scale and is interchangeable with all other Girder and Panel and Bridge and Turnpike Building Sets manufactured by Bridge Street Toys.

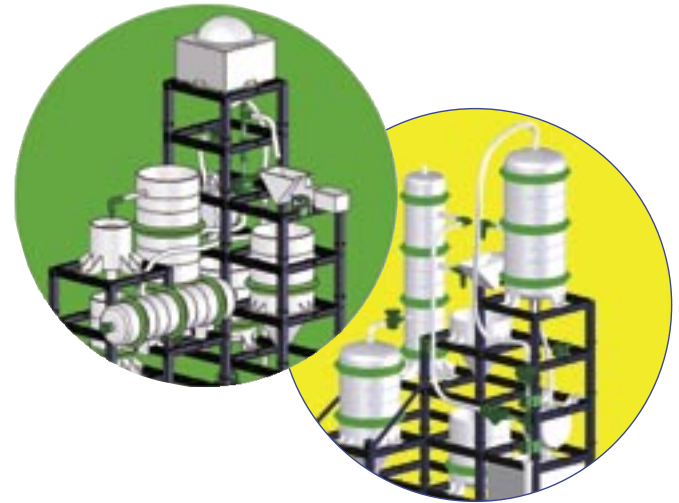

HYDRODYNAMIC Building Set Accessory Kits

Four accessory kits are available to expand your HYDRODYNAMIC Building Set. Add roadways, an office for your factory or more tanks and pipes.



Built with the Industrial Building Kit.

Industrial Building Kit

Product number: 3030HYDRO406

Small office building, 50 pcs.

Pipes and Valves Kit

Product number: 3030HYDRO706

Pipes, pipe connectors and valves, hand pump 15+ pcs.

Roadway Kit

Product number: 3030HYDRO506

Roadways, footings, signs, 48 pcs.

Spare Tanks Kit

Product number: 3030HYDRO606

Small and large round tanks, saddle, small and large collars. 20 pcs.



HYDRODYNAMIC Spare Parts

Several of the HYDRODYNAMIC tanks and pumps are sold as spare parts including the Electric Pump, Hand Pump, Siphon, Float Valve, Tilt Scale, and the Turbine Flow Meter.

HYDRODYNAMIC Building Sets, Accessory Kits, and Spare Parts are sold through educational toy stores and hobby stores. Visit www.BridgeStreetToys.com to find a retailer near you.

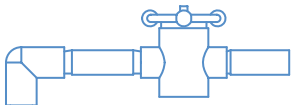

The HYDRODYNAMIC™ Building Set Pieces

(Pictured below are all the different pieces for the HYDRODYNAMIC Building Sets. The Starter Set includes several but not all of the different tanks and pumps that are available.)



footing and base



column



beam



stub



diagonal braces



tubing for pipes



large tank collar



large tank center section



float valve



large tank cone base



large tank base



large tank end section



siphon

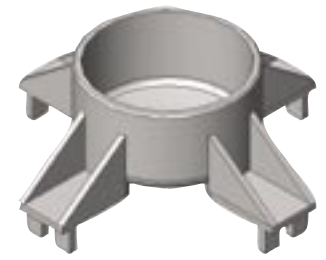

small tank base

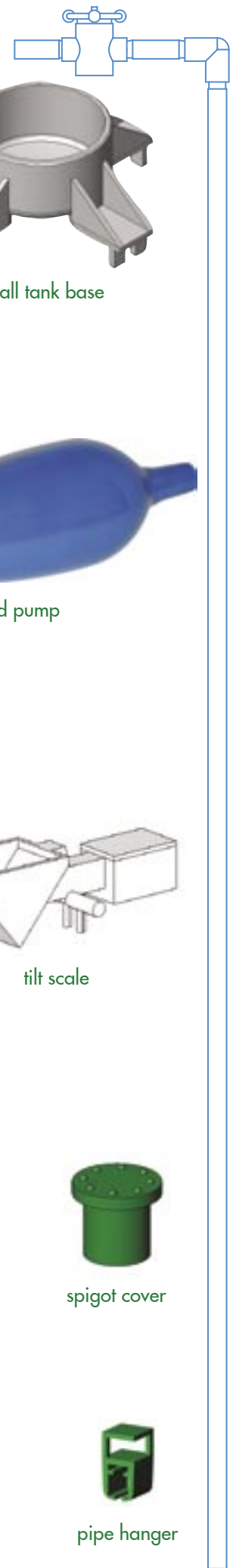

small tank center section



small tank collar



small tank end section



signs



hand pump



electric pump

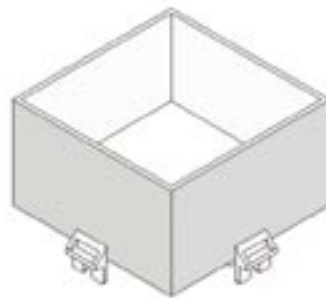

square tank base



square tank top

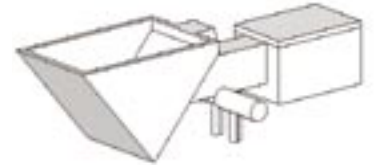

tilt scale



turbine velocity meter



spray head



horizontal tank holder small



ball flow meter



spigot cover



"L" pipe connector



straight pipe connector



"T" pipe connector



valve



pipe hanger

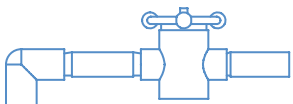

How The Parts Work

1 Build the Structure of Girders

You will build your HYDRODYNAMIC set by using the footing that is attached to the inside of the tray as your foundation. The tray acts as a reservoir for the pump.



Footing is inside the tray.

2 Insert the bottom peg of the columns into holes in the white footing. These columns will form the support for the first level of your structure.



3 Connect pairs of columns with a beam. The notch on the top of the beam slides into the top slot in the column.

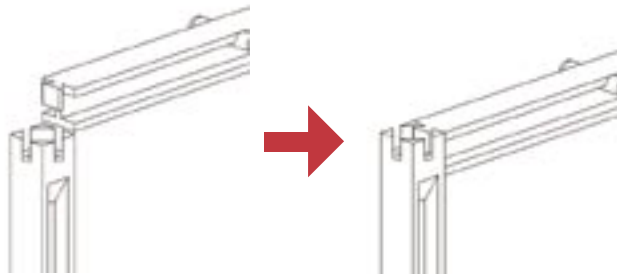

4 Use another column to lock the beams in place and construct a second level.

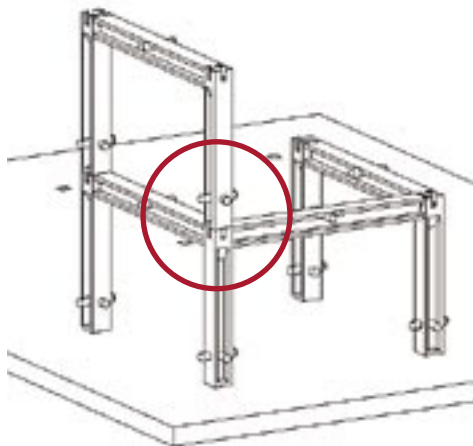

5 When you have completed two levels, you can start adding tanks. (The first level will be mostly under water when the miniature factory is operating.)

6 Add Tanks and Pipes As You Build

Continue building your HYDRODYNAMIC set with columns and beams to provide the basic structure. Assemble tanks as shown on page 8 and 9 and put the tanks in place as you build the structure. It is difficult to install the tanks after the structure of girders is made. In most cases, you will need to partially dismantle the framework in order to add tanks if the structure has been completed.

Note: The water will only flow through the tanks properly if they have an air vent. Air vents can be created by either leaving the top of the tank open or leaving one of the nozzles open - just make sure it's above the level of water in the tank!

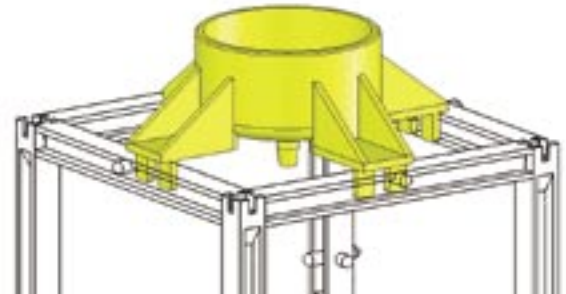

7 Attach Cross Braces and Stubs

Attach cross braces and stubs to finish the support structure. Stubs can be used both at the top of the columns to anchor the beams, provide a place to attach cross braces, and at the bottom of columns when making a cantilever structure. The cross braces can be used to add stability to the structure and support a cantilever section.

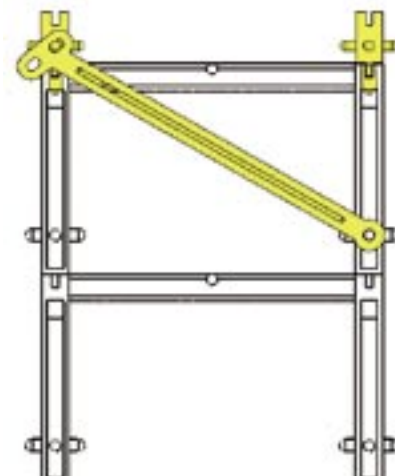

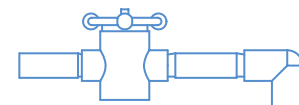

8 Add Pipes

Add pipe supports, valves, pipe fittings, and pipes. Pipes can be cut to length using either ordinary scissors or wire cutters. There are three types of joints available when you're constructing your piping - a "L" for turning corners, a "T" for joining one pipe to another, and the "Straight" is for joining lengths of pipe together.

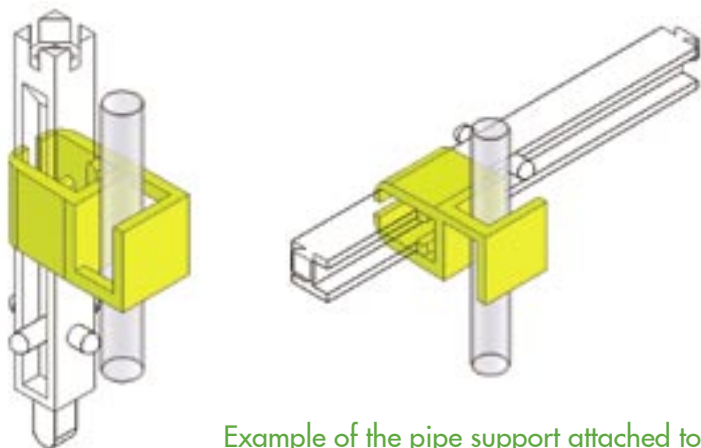

Example of the pipe support attached to a column and a beam.

9 Install the Pump

If you are building a set with a **hand pump**, connect the pipes in a way to allow the pump to rest near the bottom of the structure. The large diameter feed line should lie flat on the bottom of the tray and can be held in place with the suction cup clip provided. This is the inlet pipe for the hand pump. The hand pump also requires an outlet pipe (it is a smaller diameter than the inlet pipe) to connect the hand pump to the structure.

If you are building a set with an **electric pump**, place the pump inside the tray. The footing is positioned in the tray to leave an empty space on one side of the tray where suction cups on the bottom of the electric pump can rest on the plastic tray bottom. The electric pump requires an outlet pipe but not an inlet pipe. The pump draws water through the grating on the side of the pump.

10 Add Water

When your structure is built and piped, put the HYDRODYNAMIC set on a level surface. (This is a water toy so we recommend you choose a place that is water friendly in case some water splashes out of the tray.)

Fill the tray about two-thirds full of water (about 2" deep). The water should cover the inlet of the electric pump or cover the open end of the inlet line of the hand pump.

11 Using the Pumps

If using the **electric pump**, make sure that the transformer is connected to the pump and plug the transformer into a wall outlet (normal household 110V wall outlet). If there is a GFCI plug available, we recommend that you use it. These are usually found in kitchens, bathrooms, and outdoors. In either case, place the transformer where it will not get wet.

WARNING: DO NOT SUBMERGE THE TRANSFORMER IN WATER!

If using the **hand pump**, squeeze the bulb a few times to prime it and then water should start to flow.

12 Run It!

Adjust the valves to change the flow of water. Have fun experimenting!



Valve is Open (Full Flow)



Valve is Closed (No Flow)



Valve is Partially Open (Reduced Flow)

Hints and Tips

The first time you build with the HYDRODYNAMIC Set we recommend that you follow the progressive build instructions on pages 12 and 13. This set requires the builder to visualize their final structure with all the tanks in place before they start to build. The set is great for developing the "plan, build, test, then redo based on what you learned" thought process.

Once the builder is comfortable with the set, it is fun to add a water based food color to the water. By adding a couple of drops to different tanks in the system, flow patterns are easily identified.

A large plastic baster (sold in kitchen supply stores and most grocery stores) allows the builder to move water around from tank to tank exactly as they wish. It's fun!

Don't allow the water to sit in the tanks for more than a day, it gets stagnant. If you need to clean the set, use normal dish washing soap and warm water.

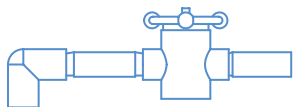

Tank Assemblies



dome cap



spray head
(optional)



collar



tank section



collar



tank section



collar

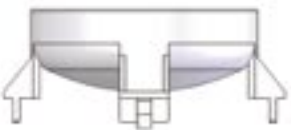

base

Float Valve

The float valve is only for use with the large round tank and round base. The round disk on the bottom of the float valve rests on the bottom of the tank blocking the outlet. As the water level in the tank rises, the float rises until the disk on the bottom is pulled up and the water is able to drain.

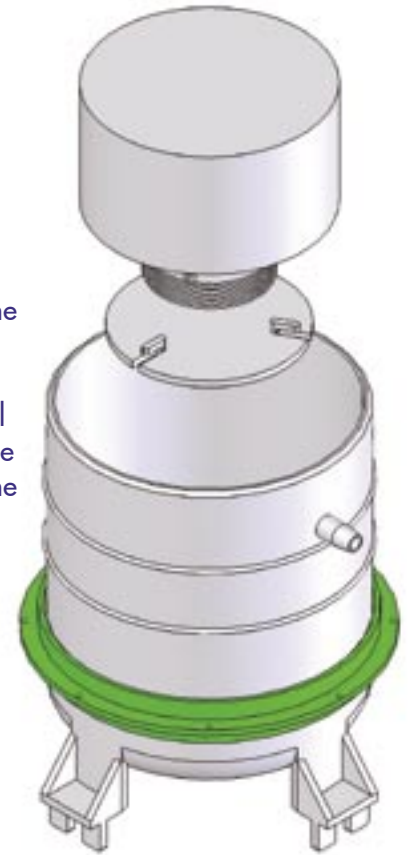

Spigot Cover



The tank pieces have several connection nozzles to allow the attachment of pipes. Spigot covers are used to close the connection nozzles that you don't use in your design. i.e. if you don't connect a pipe to one of the connection nozzles that will be below the liquid level, you should plug the hole with the spigot cover.

Square Tank and Spray Head

The spray head may be placed in the top of a round tank tower or it may be placed in the bottom of the square tank. In both cases it is important that the tank be enclosed on the top and the bottom.



spray head
(optional)

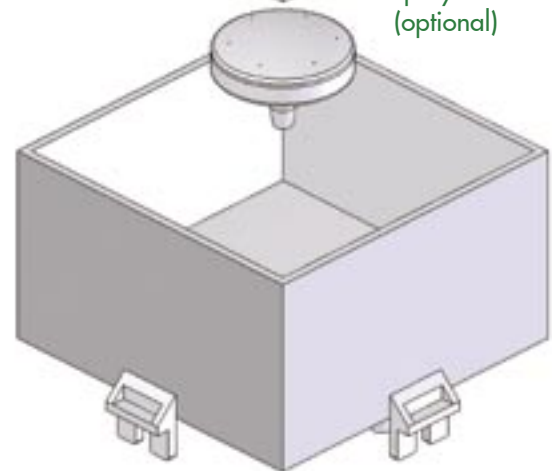

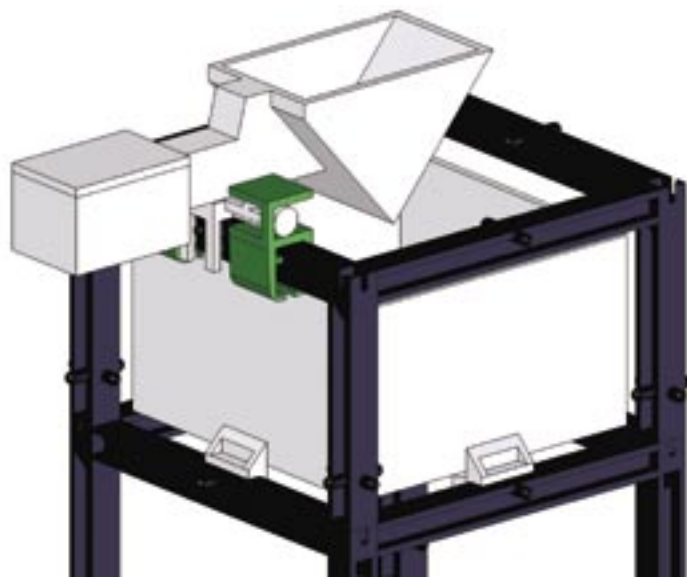
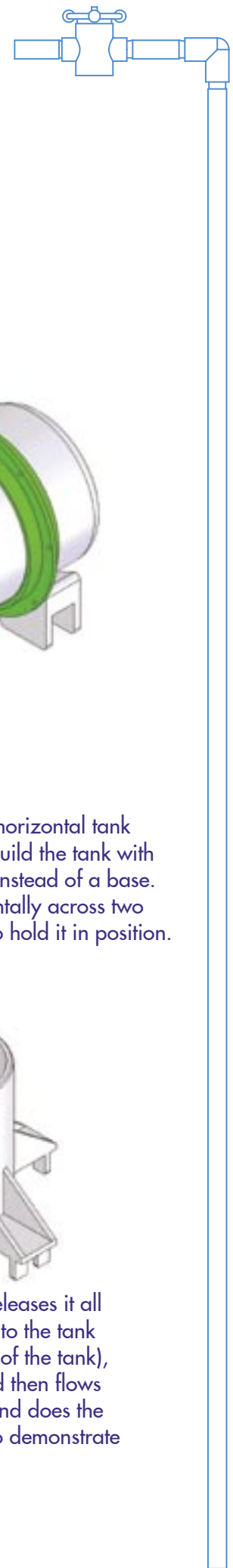

Tilt Scale

The tilt scale should be positioned over the square tank, the large round tank, or on a lower section of the structure where it can empty into the reservoir.

The tilt scale measures water by using weight. The scoop fills until the amount of water present weighs a sufficient amount to counterbalance the weight on the other end of the tilt arm and thus empties.



Ball Flow Meter

The ball flow meter is placed in-line with the piping. It should be positioned with the wide end up. When the ball inside is at rest on the bottom of the tube, there is no flow. When the ball is at the top of the tube, there is full flow. The height of the ball indicates the amount of flow through the pipe.

The ball also acts as a "check valve" as it blocks the outlet on the bottom of the flow meter when the water stops flowing. Thus, any water in the system above the flow meter is trapped as it can not flow backwards through the ball flow meter.

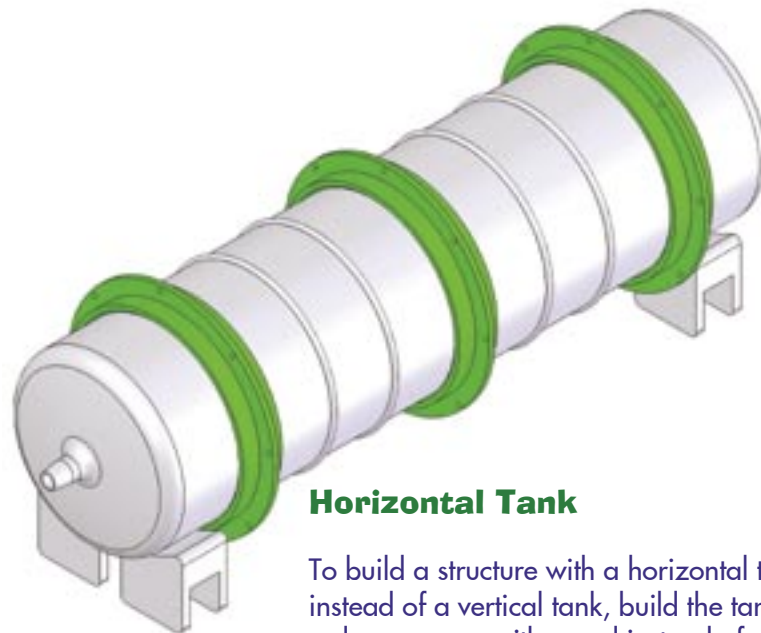

Horizontal Tank

To build a structure with a horizontal tank instead of a vertical tank, build the tank with a dome cap on either end instead of a base. Then place the tank horizontally across two beams, using the saddles to hold it in position.

Turbine Velocity Meter

The turbine velocity meter is another device for indicating the amount of flow through the system. The more flow, the faster the wheel will turn. You can control it's speed by placing a valve in the inlet pipe.

Don't connect anything to the outlet.

A pipe on the outlet causes enough flow resistance so that the water will back up into the turbine and cause the wheel to stop spinning.

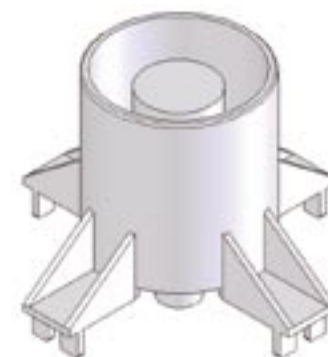
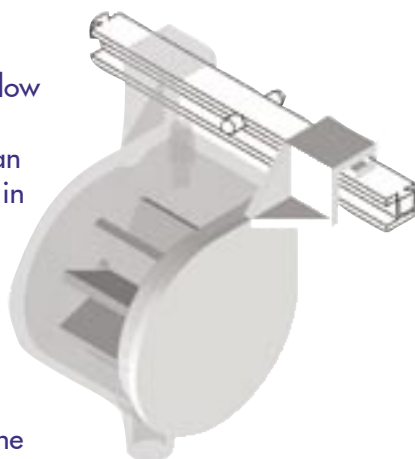

Siphon Tank

The siphon tank collects water and then releases it all without any moving parts! Liquid flows into the tank from the top (position a pipe over the top of the tank), collects until a certain level is reached and then flows out until the tank is empty. It then refills and does the same action again. This is a great tank to demonstrate the principles of a siphon!

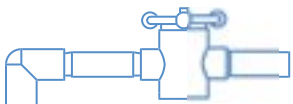

Built with the Starter Set (HYDRO206)

Toothpaste
Factory



Paint
Pilot Plant

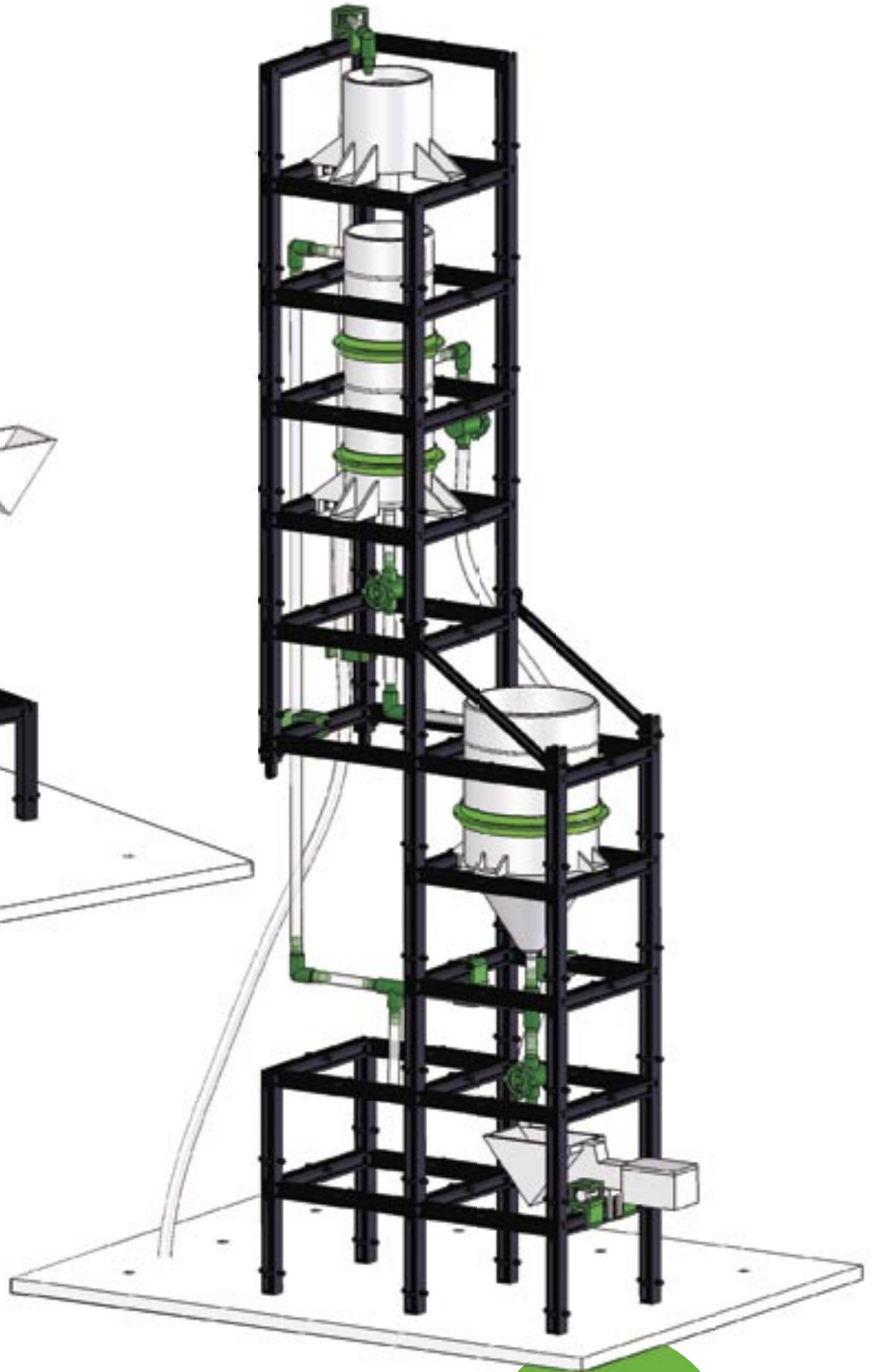
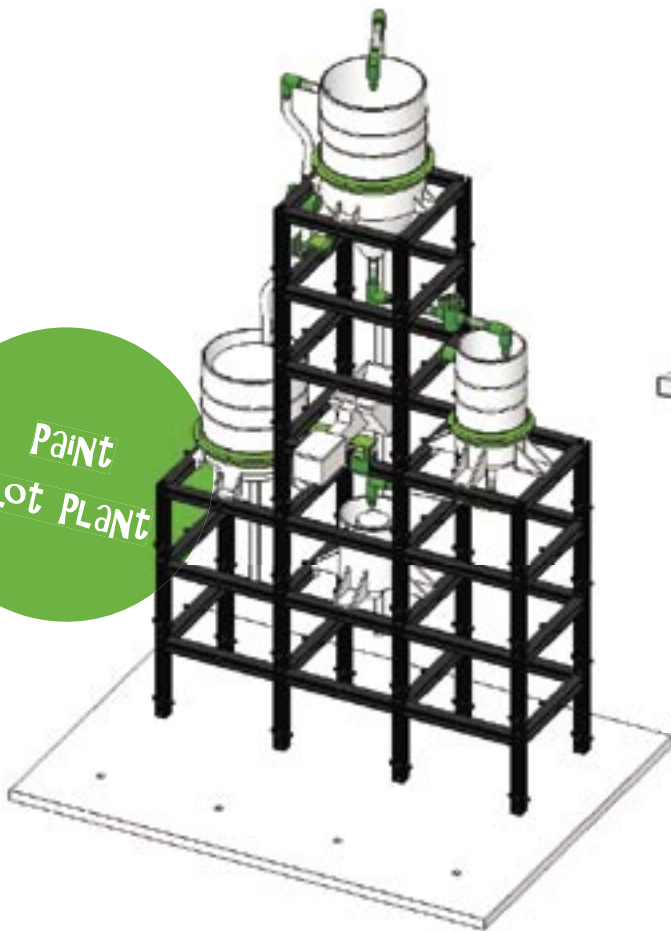

Vinegar
Production
Facility

Built with the Deluxe Set (HYDRO306)

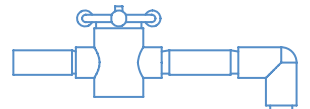

PLASTICS
PLANT

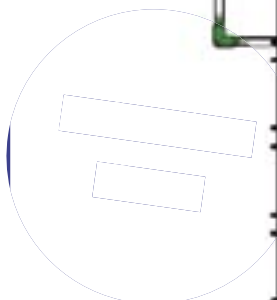
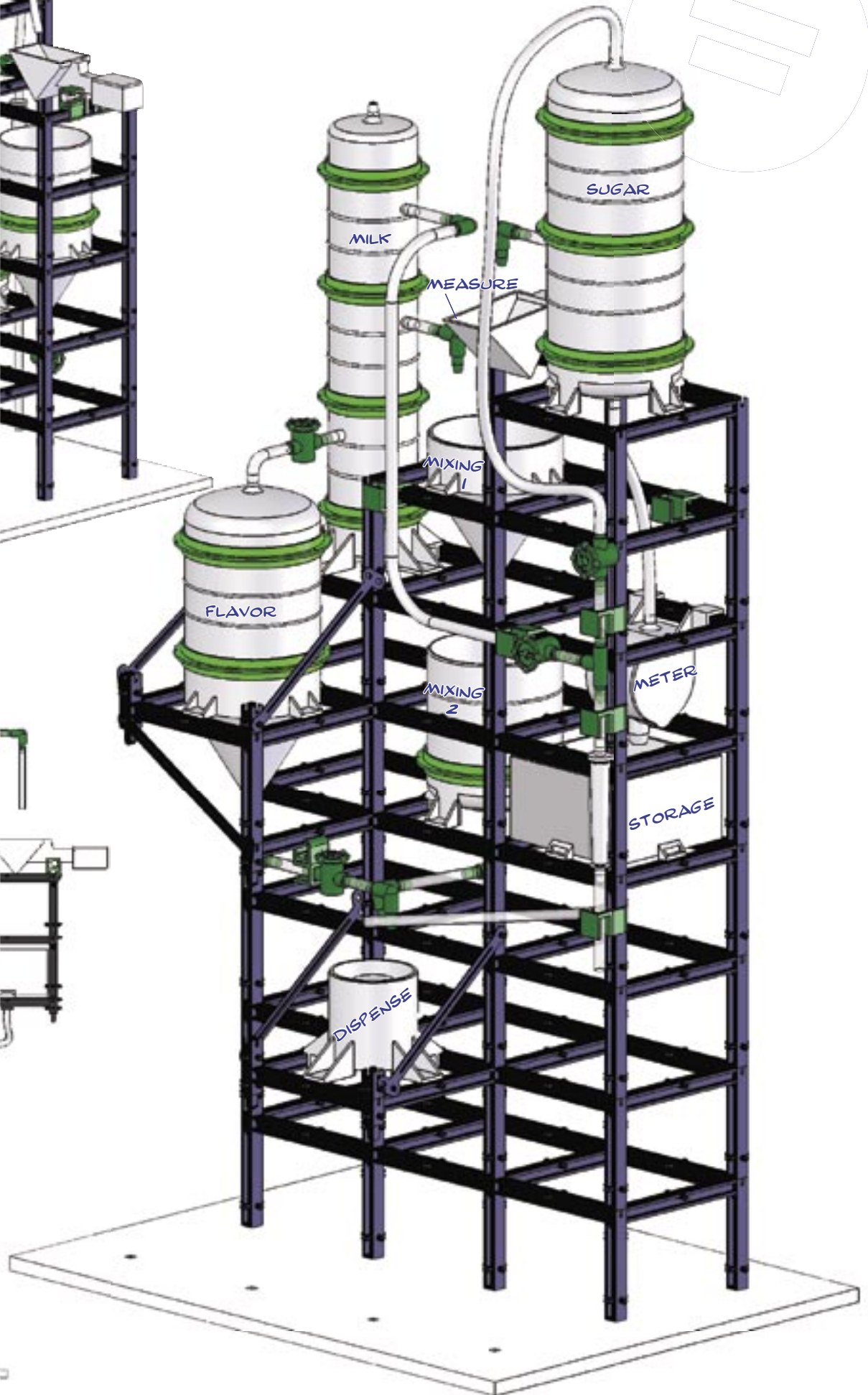
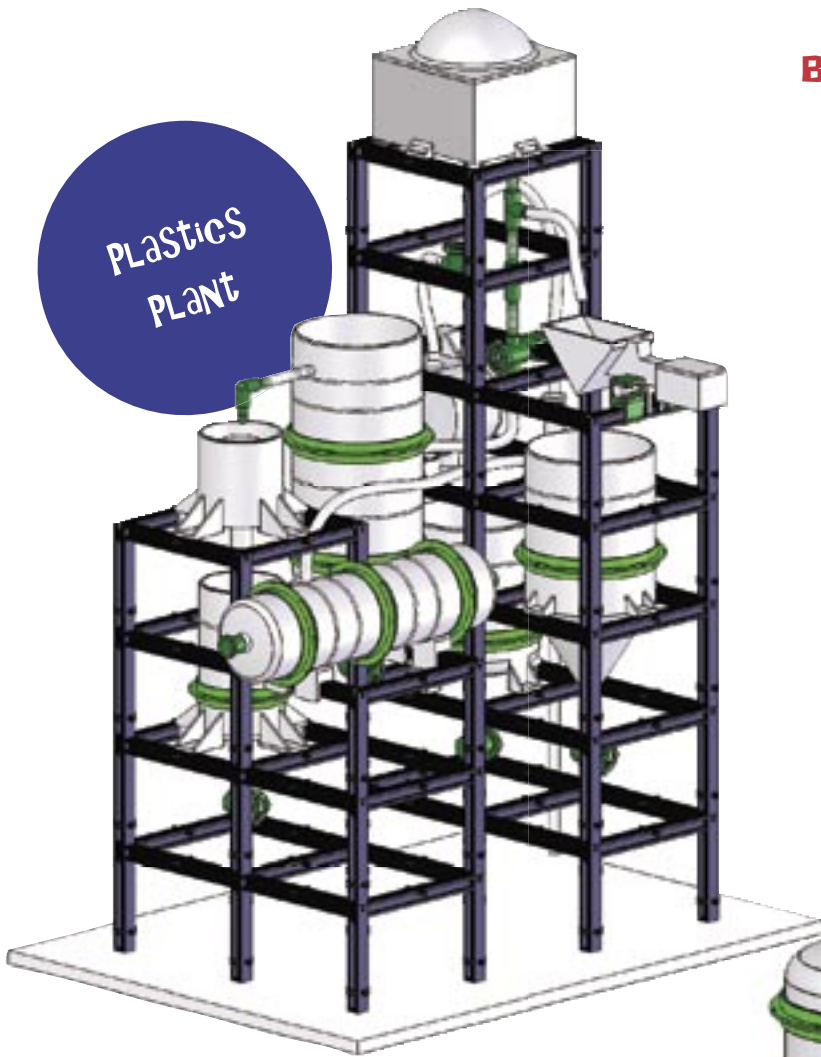

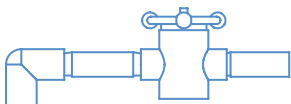

Progressive Building Instructions

Step 1

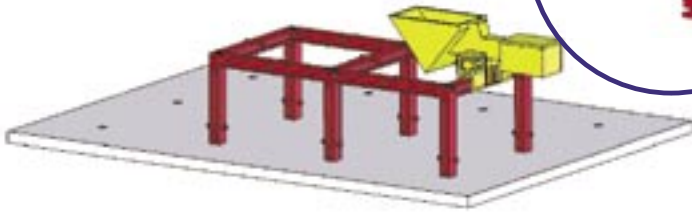

Step 2

Step 3

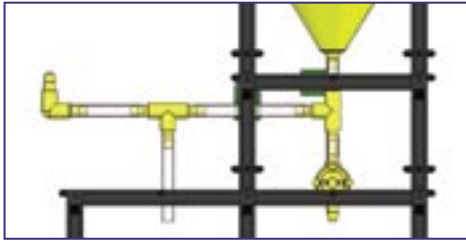

Step 4

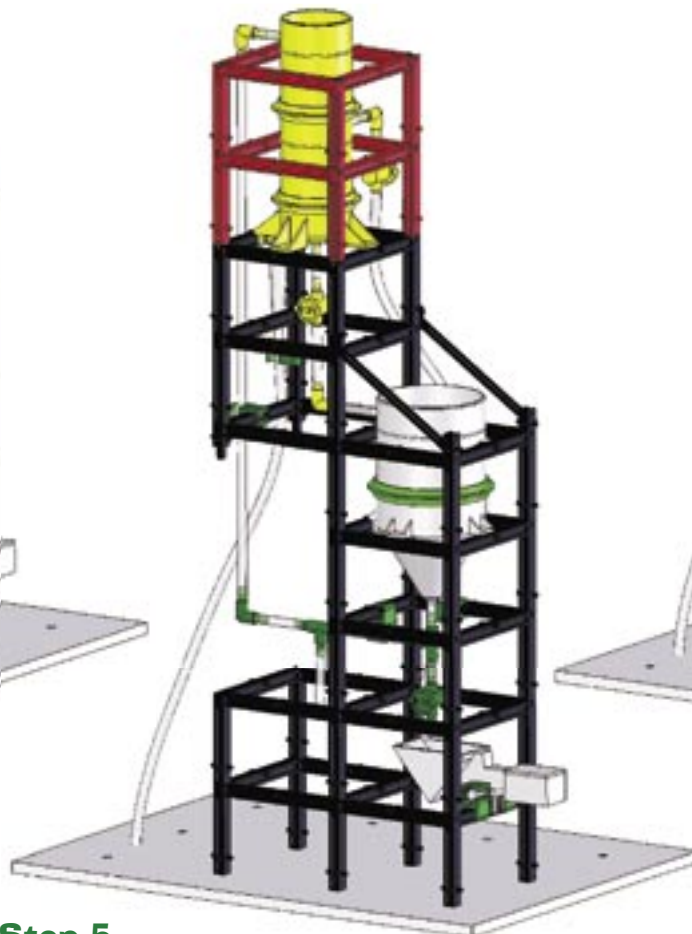

Step 5

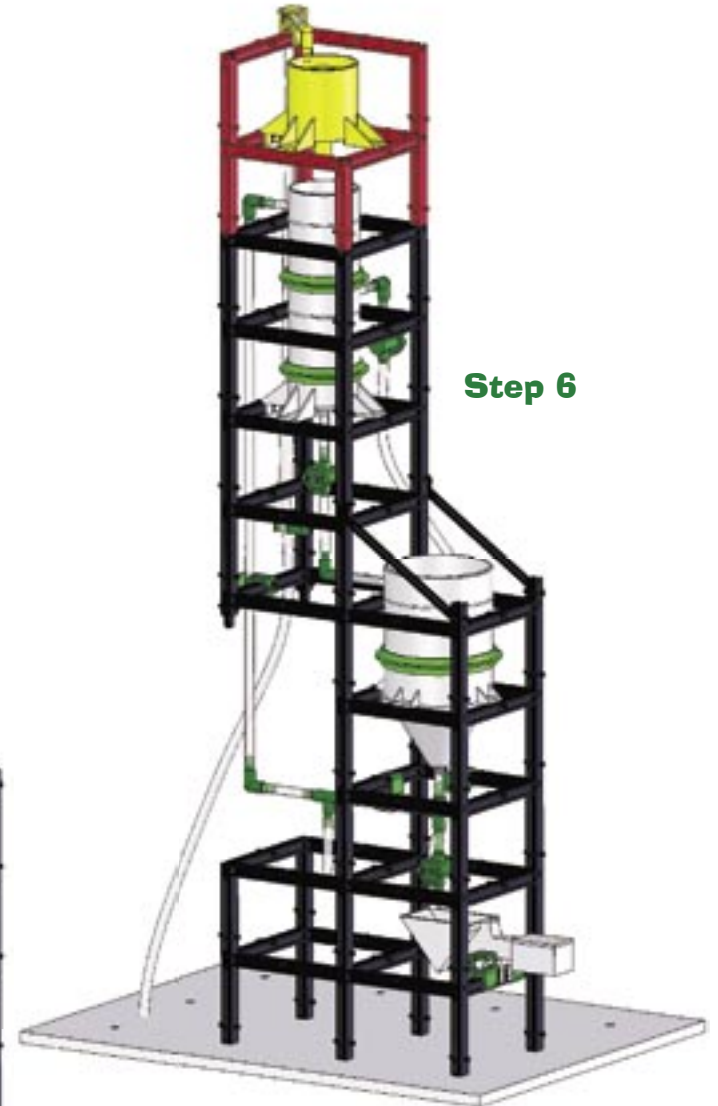

Step 6

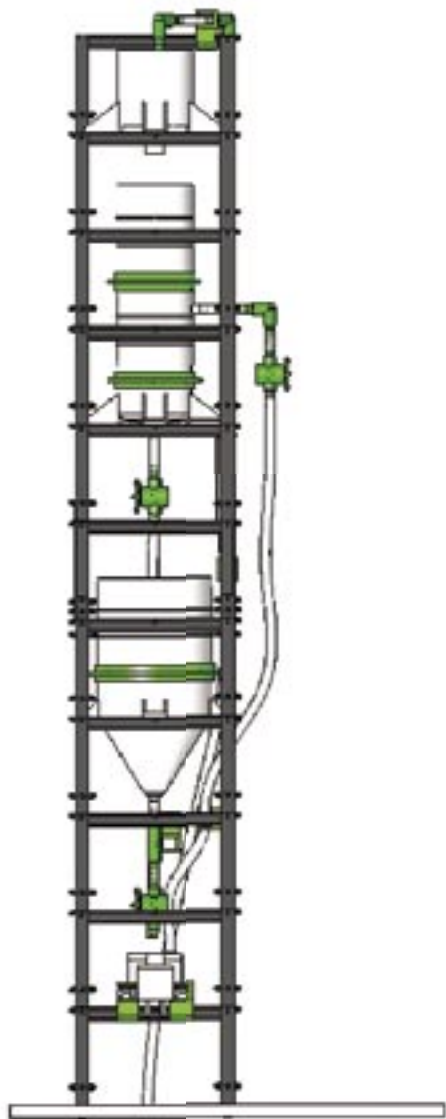
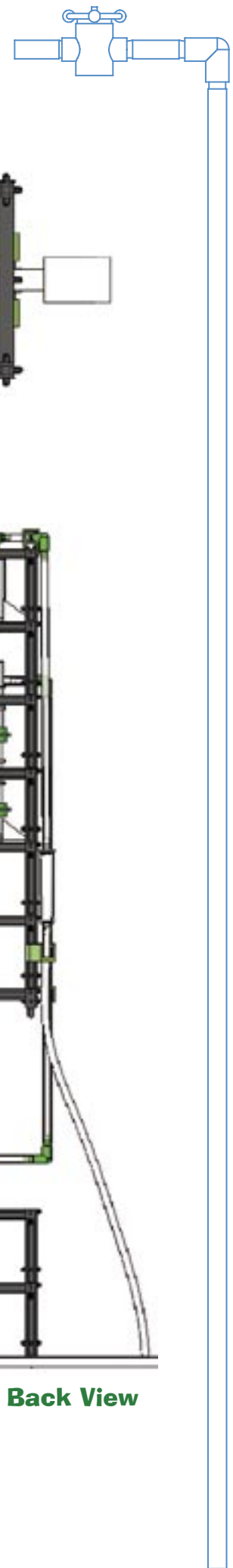

Completed Model - Side View

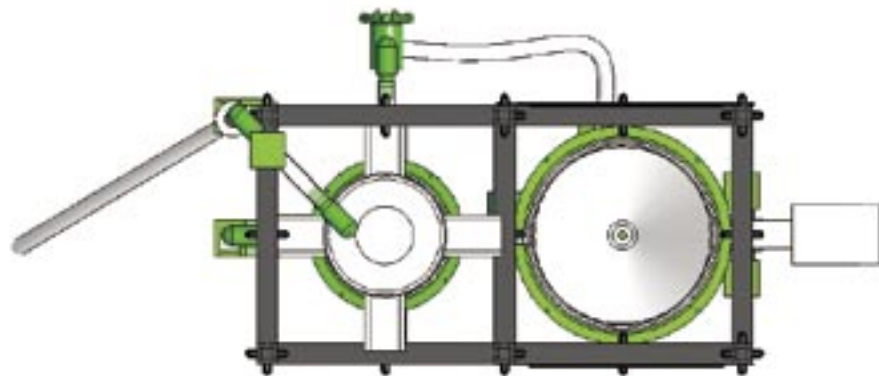

Completed Model - Top View

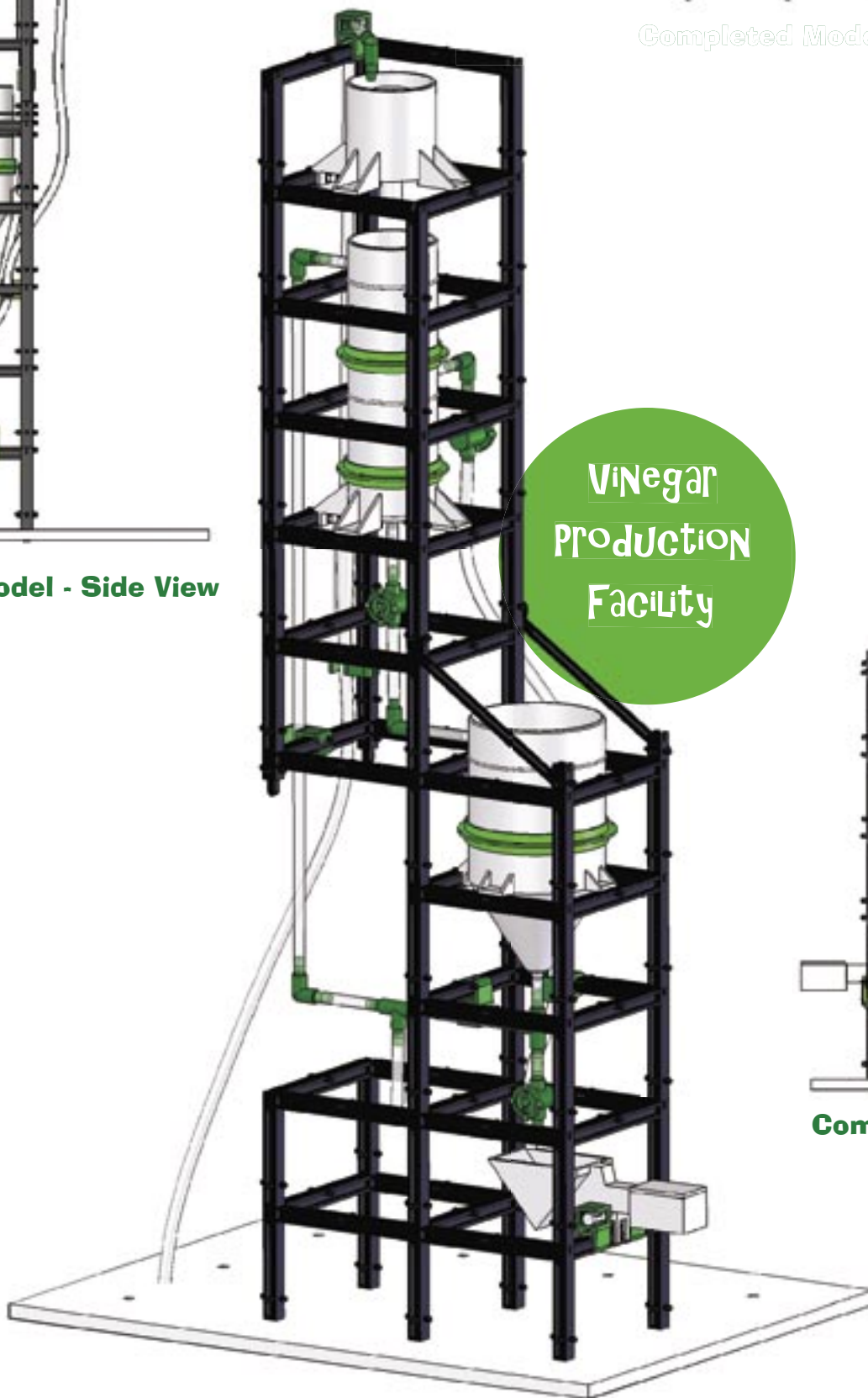

**Vinegar
Production
Facility**



Completed Model - Back View

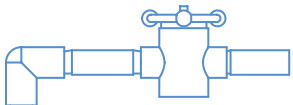

Schematic of Ice Cream Factory Model

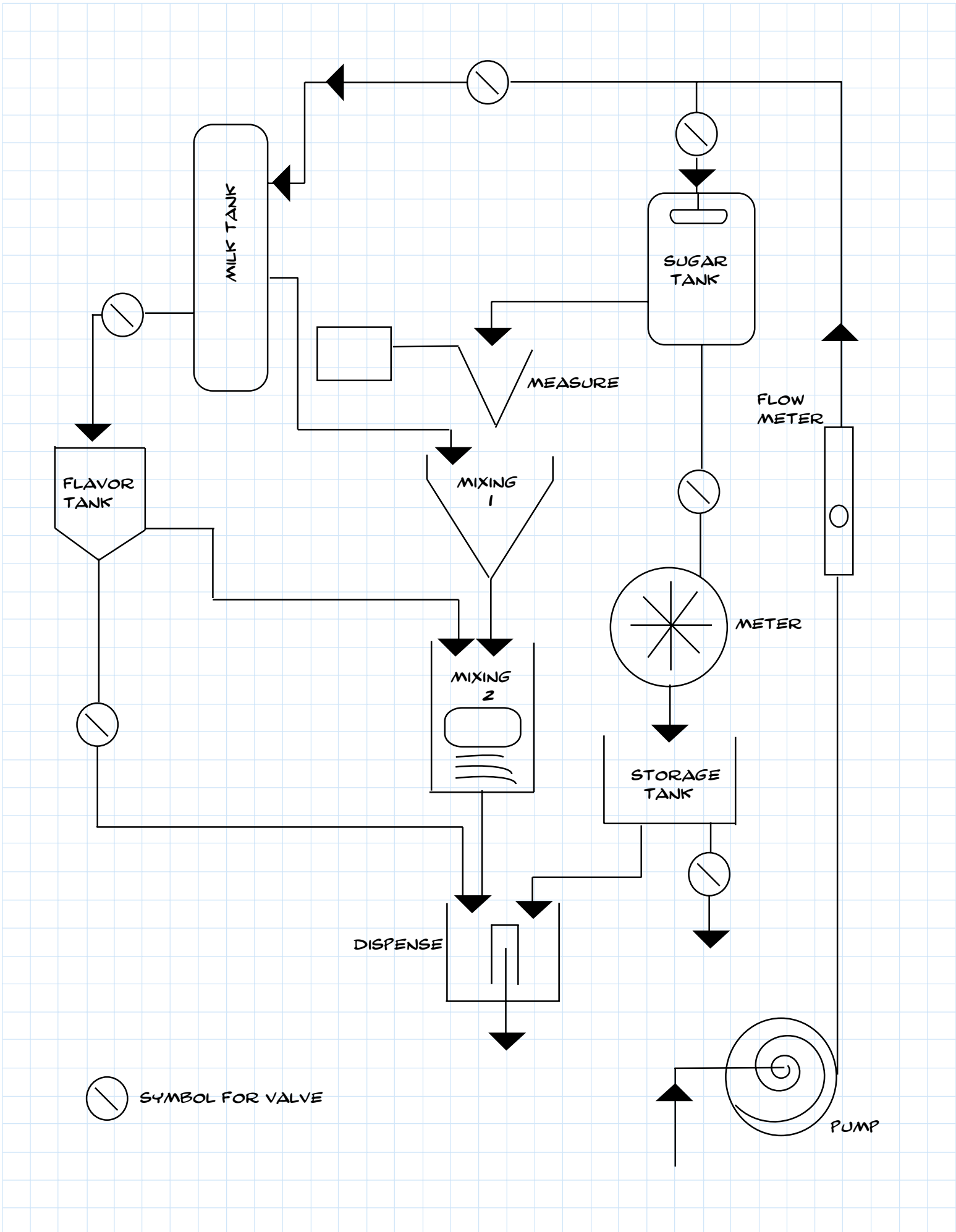

 SYMBOL FOR VALVE

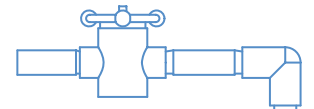

Ninety-seven percent of the earth's water is found in the oceans and is too salty to drink. More than 2% is either frozen or trapped in the ground. This leaves less than 1% of all the water on earth available for people to drink.

Water is a unique substance. Most compounds become more dense as they cool, but water molecules actually spread out as they freeze, making ice less dense than liquid water. That's why ice floats! Try it.

In the 14th century B.C., the Egyptians used water clocks to keep track of the time. A small hole in the bottom of a pot allowed water to drip out slowly. By checking the level of the water remaining in the pot, they could tell how many hours had gone by.

Although many different types of valves are used to control the flow of fluids, the basic valve types can be divided into two general groups: stop valves and check valves. Stop valves are used to shut off the flow of fluid. Stop valves are controlled by the movement of the valve stem. Stop valves can be divided into four general categories: globe, gate, butterfly, and ball valves. Check valves are used to allow fluid flow in a system in only one direction. They are operated by the flow of fluid in the piping. A check valve may be the swing type, lift type, or ball type.



A Stop Valve

Engineers study ways to make ice-cream creamier by studying the size and shape of the microscopic ice crystals that form this tasty treat.

A strong pump can "push" water hundreds of feet high, but no pump can pull water more than 32.2 feet. This is why pumps are located on the lower floors of skyscrapers rather than on the top floors.

Modern day chemical factories are built within spill containment facilities. If a pipe breaks, a tank leaks, a seal fails, or the wrong valve is opened, all material will be contained at the factory rather than contaminating the surrounding environment. The containment facility is sized to hold the entire contents of the tanks inside plus more for added safety. The tray for your HYDRODYNAMIC set is the containment facility for your factory. If you leave the wrong valve open by accident, the water will be contained!

Chemical engineers supervise the operation of chemical plants, redesign chemical processes for pollution prevention and develop new products. Chemical engineers work in the petrochemical industry, in the pharmaceutical industry, in the food industry, in the chemical industry and in the electronics industry.

If a pump's inlet is restricted, destructive bubbles can be formed in the fluid being pumped. This is called "cavitation." Cavitation causes a lot of wear on pumps.

Other Things to Investigate With your HYDRODYNAMIC™ Set

While you will spend many enjoyable hours building models and playing with the water flow, the HYDRODYNAMIC Set can be used for much, much more! Use your imagination to investigate how things work! Ask a question, then use the set to help formulate the answer - for example:

Can you explain how a siphon works?

Investigate what happens when a tank is not vented versus when it is vented. Why does it make a difference?

Build a model of the water cycle.

The HYDRODYNAMIC Set is a great tool for conducting science fair projects! One project idea is listed below to get you started.

What Filter is Best For Cleaning Water?

A project for ages 12-14

Project uses household materials to create filters to test which is best for cleaning dirty water.

Summary

Water is essential for life. Although water covers nearly $\frac{3}{4}$ of the earth's surface, only a small amount of it is available to use. The water on earth is part of a closed system, the Water Cycle. No new water is made, it simply follows a cycle of evaporation and condensation. Keeping the world's supply of water clean is a big challenge. This project compares the filtering quality of different substances.

To determine the best way to filter dirty water and make it clean you will need:

1 HYDRODYNAMIC™ Deluxe Building Set
and
Dirty Water (Such as Pond Water)

- Coffee Filter
- Paper Towel
- Small Sponge
- Charcoal Briquette
- Small Sieve
- Handful of Rinsed Sand
- Nylon Stocking



Have a Problem Or a Question?

Contact Us

Please let us know if we can help you.
customerservice@BridgeStreetToys.com
1-781-237-5005

Have a Great Idea?

Do you have a great idea for a building and want to share it with other builders?

Send it to us at: funstuff@BridgeStreetToys.com

We will post pictures of creative buildings on our website's *Hall of Fame* page.

p.s. Please send your photo in "jpeg" format and include your first name and age.

Need More Parts?

No problem. We are selling spare parts! Check with your favorite educational toy shop, or hobby store, if they're not available there you can order them online through our website:
<http://www.BridgeStreetToys.com>

Our Promise to You

We guarantee our products to be free of materials and manufacturing defects. Should your building set have a defect which makes the set unusable, please contact our customer service department for a replacement product.

